

MAKE AN ORIGAMI KITE BOOKMARK

Create a kite bookmark inspired by the exhibition
Kite-Flying Foibles, on view
through September 17, 2023.

*Yellow indicates the front of the paper and
white indicates the back.*



1. Fold your paper in half lengthwise and crease firmly. Unfold.

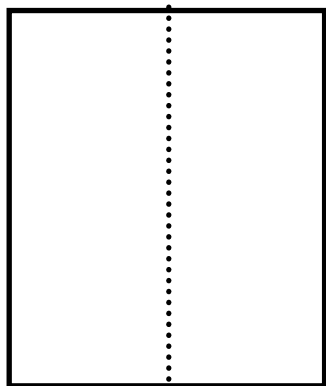

2. Fold the top-left corner down to meet the center crease. Repeat on the right side and tape the flaps together in the center.

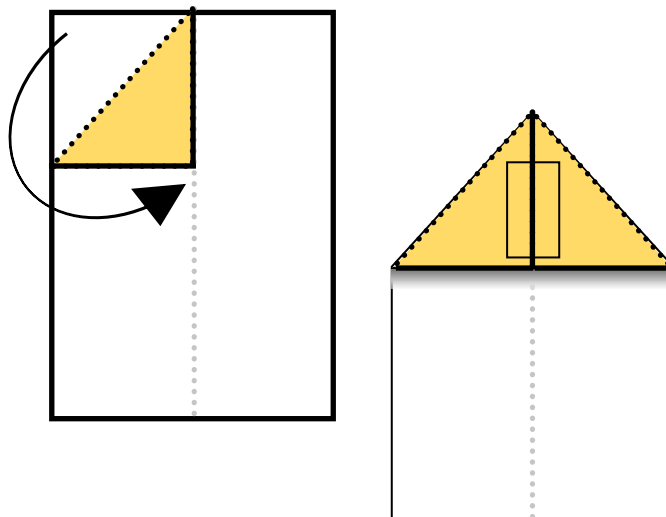

3. Make a new fold on the left side extending from point "A" on the diagram below to the midpoint on the bottom of your kite. Repeat for the right side from point "B".

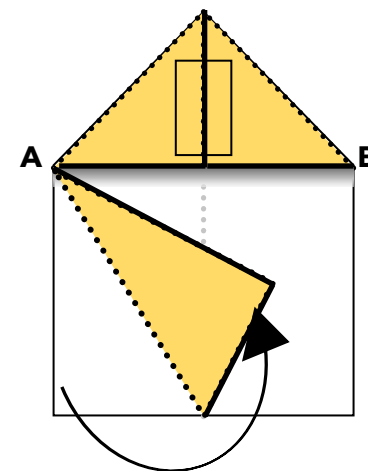

CONTINUED ON BACK →

4. Take a string. Open the bottom-right flap and lay your string in the crease. Secure with tape.

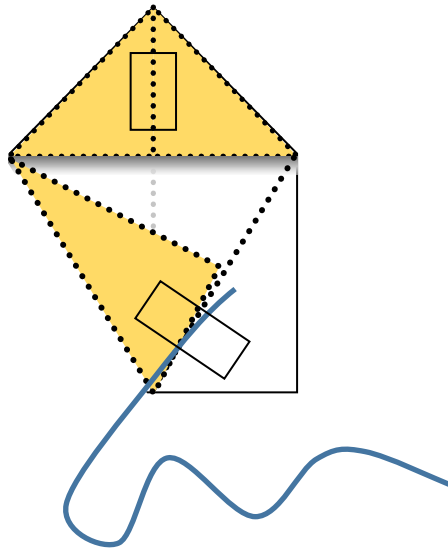

6. Re-fold the bottom-right flap of the kite and tape both of the bottom flaps down.

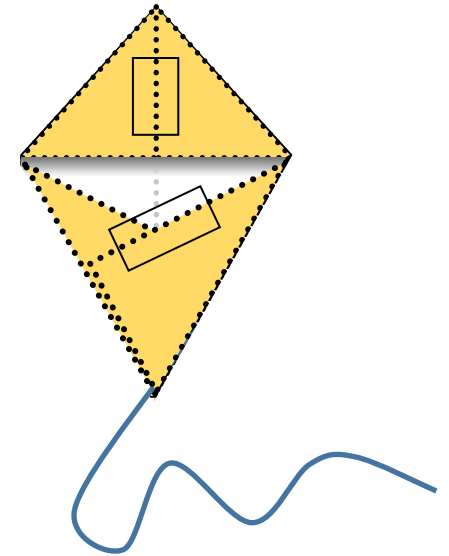

7. Decorate your kite!

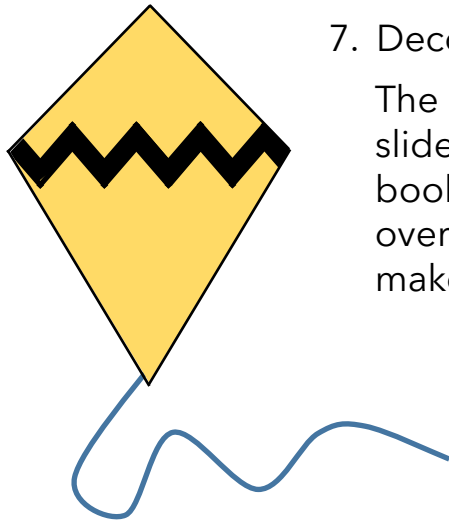

The pocket made in step 2 slides over the corner of your book page, or you can slide it over your first two fingers to make a finger puppet!



ABOUT THE EXHIBITION

Explore kite-flying with Charlie Brown and the *Peanuts* Gang and get swept away by original comic art and vintage *Peanuts* products. Beware, you may even encounter a Kite-Eating Tree! On view through September 17, 2023.

schulzmuseum.org/kite-flying-foibles